

KWELA!
FROM South Africa



Type **KTI** Kit assembly instructions

KWELA TONES

Headphone Amplifier

<http://www.lintaudio.co.za/gallery/kwelatones.pdf>

June 2020

Introduction

The **KWELA TONES** is a South African clone of a very renowned headphone amplifier originally designed by Pow Chu Moy.

Why **KWELA TONES** ? Its made in a tin...Kwela is South African music made with a tin whistle ! So why not !

The headphone amplifier is designed around a dual-channel op amp such as TI s OPA1642 or TL 072 (page 31)

However, a wide variety of Op Amps have been successfully implemented. As the Op Amp directly drives headphones some care should be given when choosing an op-amp, some op-amps are not suitable for such low impedance loads and will result in poor performance.

A TL072 is supplied to experiment with and this is known as “rolling” (page31)

The amplifier's design is quite simple. It consists of only a few components, can be assembled on a small printed circuit board, has a lower parts cost than other headphone amplifiers, and can run for many hours on two 9 volt batteries. Our tests show at least 80 hrs on a set !

The CMoy headphone amplifier can be fitted into a Fisherman's friend tin and can often be found for sale in Dischem. Other suitable tins are the Lindt chocolate heart shaped tin. Cigar boxes also work well.

A typical CMoy consists of two identical AC coupled non inverting amplifier circuits each with a 100k Ω input impedance.

Power is supplied to the op amps using a dual power supply, which effectively divides the input voltage source in half to create a virtual ground.

Contents

Part 1 – Operation

User guide

Headphone amplifier connection details

Use 2 x PP3 batteries

Part 2 - Kit Assembly

KWELX TONES Schematic

BOM

Overlay component by part number

Overlay assembly by component values

Soldering with examples of a dry solder joint

Cable “Left and Right” connections

Resistor component codes

Bending component leads

Capacitor codes

Preparing materials

PCB assembly

Preparing materials

Preparation of the tin for drilling (2 types of tin)

Pre assembly of tin before drilling

PCB assembly

Op Amp connections

Connect the audio output jacks

Connect cable to controls

Volume control connections

Now the cables

LED window

Testing

Before closing the lid, ensure nothing fouls, fit knobs and you are good to go....

Op Amp rolling

WARNING



Part 1- Operation

Thank you for purchasing a **KWELX TONES** headphone amplifier kit.

The **KWELX TONES** kt1 is designed to provide many hours of entertainment in usage.

The design has been developed primarily to enhance headphone sound performance.

Most headphones commercially available will function with the amplifier as the control circuit uses high quality materials.

The unit is NOT a hifi amplifier and is not intended for such usage. It does however perform exceptionally well with a normal MP3, cellular telephone or other audio source.

If using a Android cell phone, some outstanding DAC improver (digital to analogue converter) music player apps are available in the play store. This will provide a outstanding sound source.

Ensure all connected devices are earthed and use shielded cables. All connections to be clean and corrosion free.

User guide

The kit is complete for the operation types as listed above, so purchase cables as required, these are freely available.

Ensure batteries are fresh to ensure smooth sound quality, 2 x PP3, 9 volt type

Connect to the audio input device with the audio in socket

Use a high quality standard three pole AUX cable that are freely available

Connect headphones to the output socket, 3,5 mm 3 pole are fine

Your phone may have a app available that is a improvement over the standard audio output

Look for a app that is a DAC, this is a digital to analogue converter, this may improve the way sound is played by your cell phone.

NOTE

Avoid listening at too high a level to prevent hearing damage.

Enjoy your Kwela tones

Headphone amplifier connection details

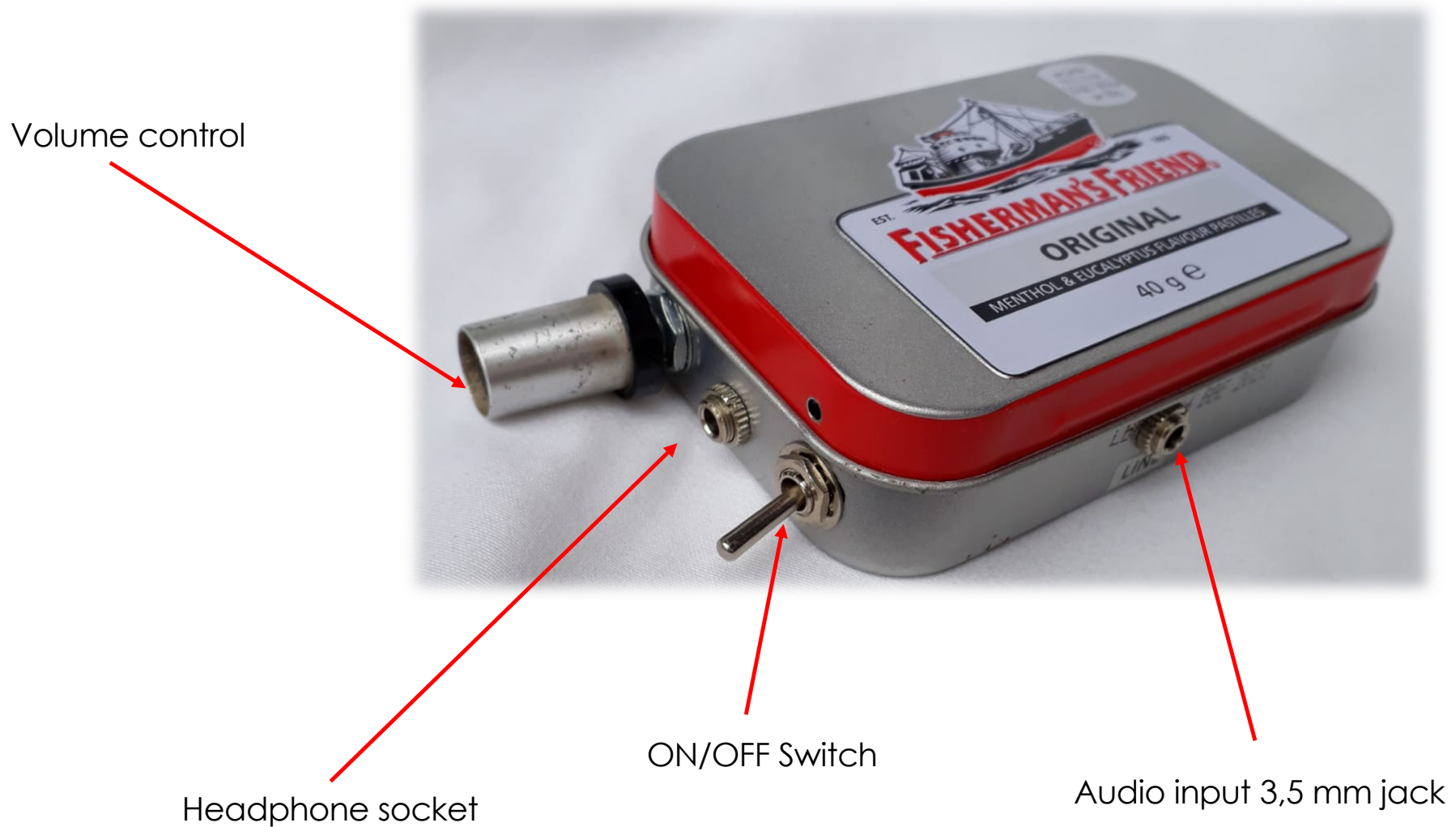

Use 2 x PP3 batteries



Part 2 - Kit assembly

Tools required

It is expected that the kit builder has some soldering experience. Always use a fine tipped soldering iron.

It is not advisable to use a heavy industrial unit.

Use fine solder when assembling.

Some basic tools are required for assembly.

A soldering station, a small screwdriver, small side cutters, pointed nose pliers, a small craft knife and ruler. A multimeter is advisable to check voltages and polarities. A drilling machine, a 1,5 mm drill bit, 7mm and 6 mm drill bits are required. A small toothbrush and benzine to clean the pcb after soldering.

A smartphone will aid in determining left and right headphone connections when connecting. Download a "left and right" app from a app store as this makes it very simple to set the correct speaker when assembled.

Benzine and a small toothbrush will be required to clean the printed circuit board when complete.

The kit is supplied as a complete package, the assembled kit works and has been in service. It performs to expectations. A enclosure is not provided.

When assembling, ensure that components are not overheated by poor assembly equipment.

When using soft solder, always wash hands before consuming foodstuffs, avoid contact with lead.

KWELX TONES Schematic

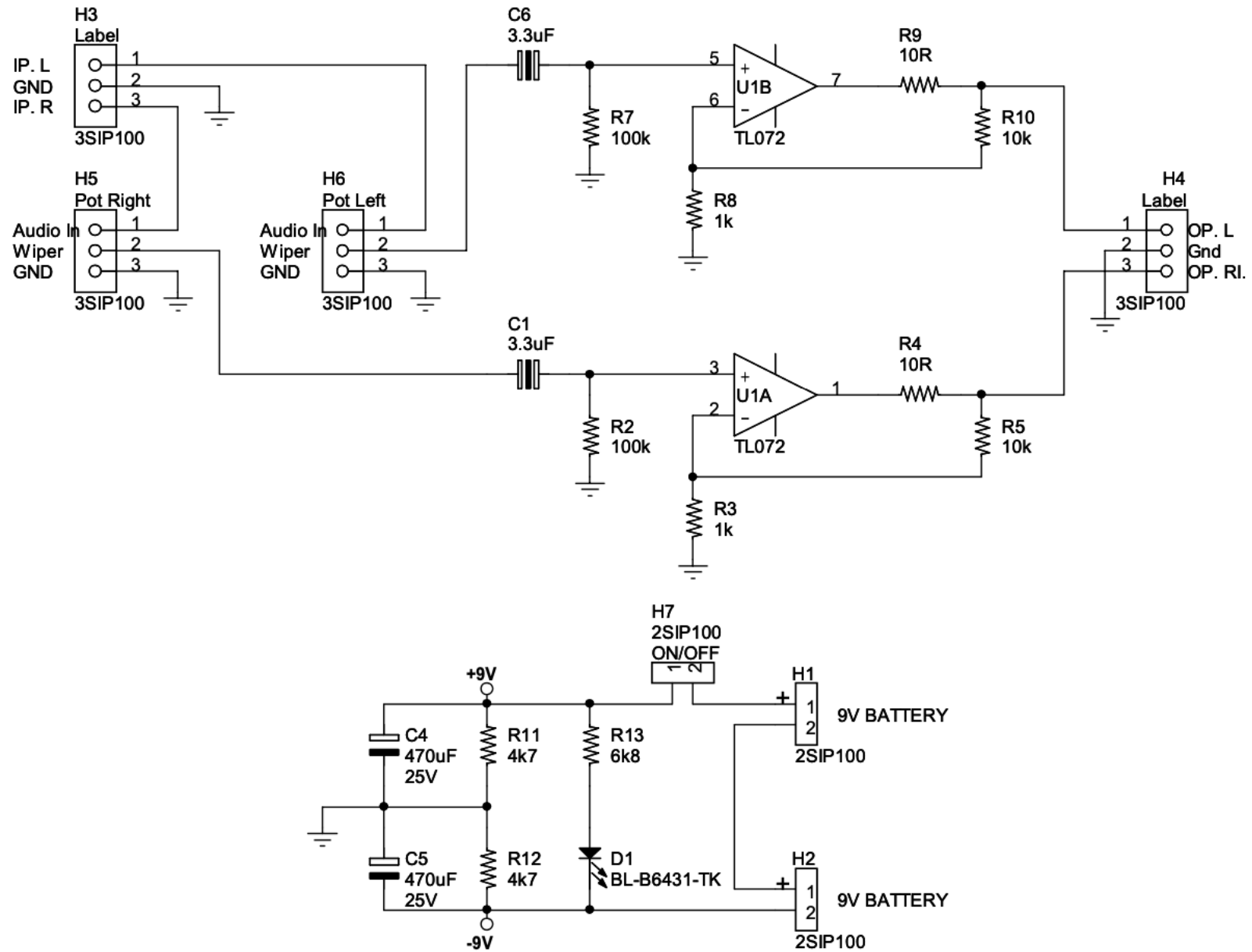

Item	Qty	Ref	Value	Description	Comments
	1	2 C1,C6	3.3uF	Cap Bipolar	Maybe swapped out
	2	2 C4,C5	470uF	Cap. Radial Electrolytic	
	3	1 D1	BL-B6431-TK	LED 3mm RED	Cololur maybe changed
	4	3 H1,H2,H7	2SIP100	Pin Header Single Row	Pads on PCB
	5	4 H3,H4,H5,H6	3SIP100	Pin Header Single Row	Pads on PCB
	6	2 R2,R7	100k	Carbon Film	
	7	2 R3,R8	1k	Carbon Film	
	8	2 R4,R9	10R	Carbon Film	Precision device
	9	2 R5,R10	10k	Carbon Film	
	10	2 R11,R12	4k7	Carbon Film	
	11	1 R 13	6k8	Carbon Film	
	12	1 U1	TL072	Dual FET INPUT OP. AMP.	Maybe swapped out
	14	1 R14	A10k	Dual Log PCB pot	
	15	1 KB1		Volume knob	
	16	1 S1		SPST on/off	
	17	2 SKT1/2		3.5 mm stereo jack socket	
	18	2 BATplug		PP3 Battery leads	
	19	2		PP3 batterys	Originals give 36 hrs
	20	1 PCB1		PCB	
	21	1 V1		Vinyl sheet	Must be cut to size
	22	1		0,2 mm red wire	
	23	1		0,2 mm orange wire	
	24	1		0,2 mm yellow wire	
	25	1		0,2 mm red wire	
	26	1		Solder wire	
	27	2		Spacer for knobs	
	28	1		Heat sleeve	
	29	1		Press stik	
	30	6		Cable ties	
Optional					
	31	1		Red RCA socket	
	32	1		Black RCA socket	
	33	1		Siemens 1 uf	
	34	1		2,1 mm power socket	
	35	1		2700 uf capacitor (axial)	
	36	1		100 nf capacitor 100 v	
	37	1		Cable saddle	
	38	1		Capacitor plate	
	39	1		OPA 1642 (and adaptor)	
	40	1		Mtg plates with screws	

Notes

Op Amp may be changed to suit Individual styles.

Batteries available from Clicks at R45, Dischem are R39,00

Other tins maybe used or a similar style enclosure.

CI and C6 maybe substituted to suit

Overlay component by part number

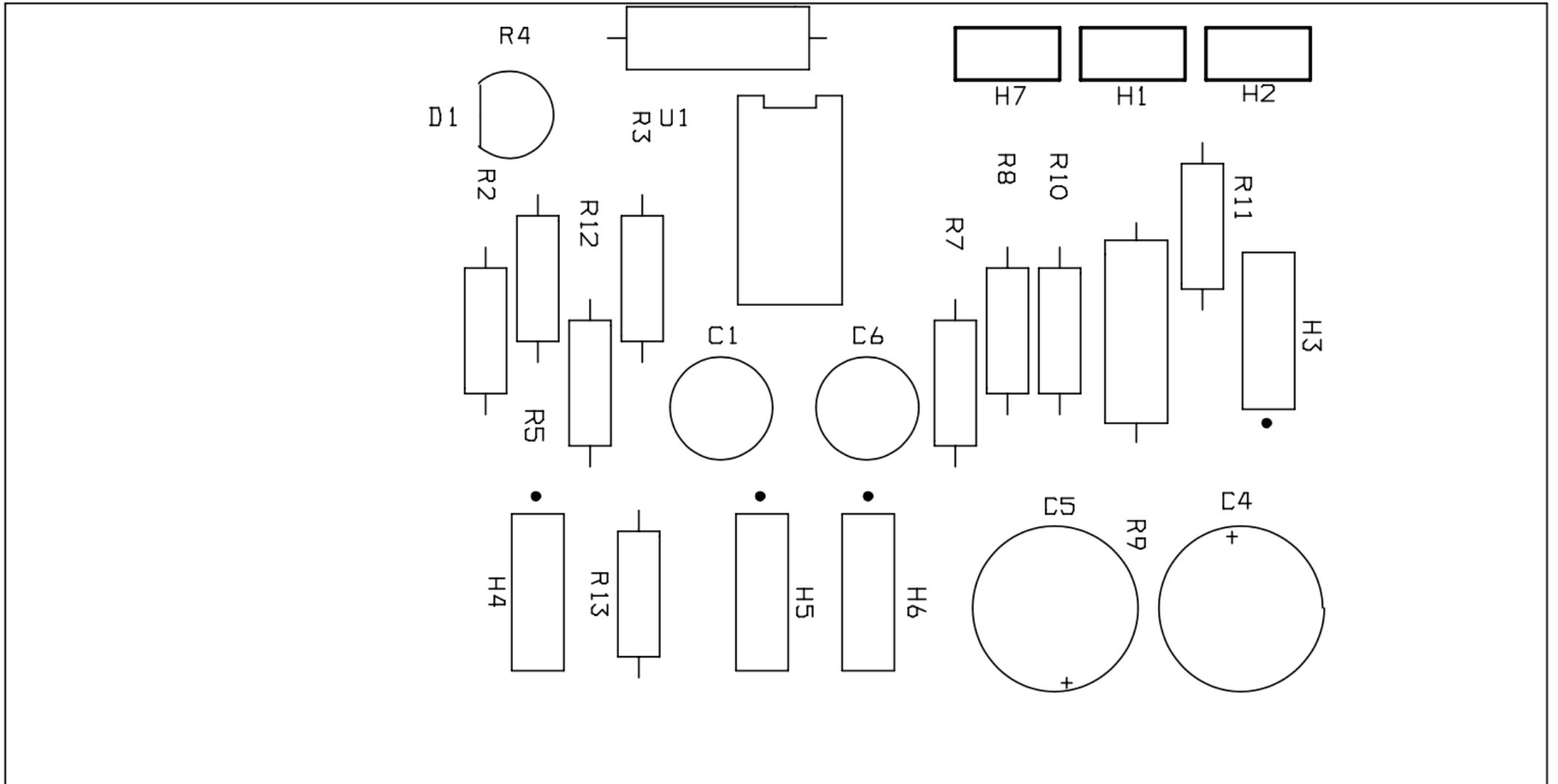

Silkscreen - Top

Overlay assembly by component values

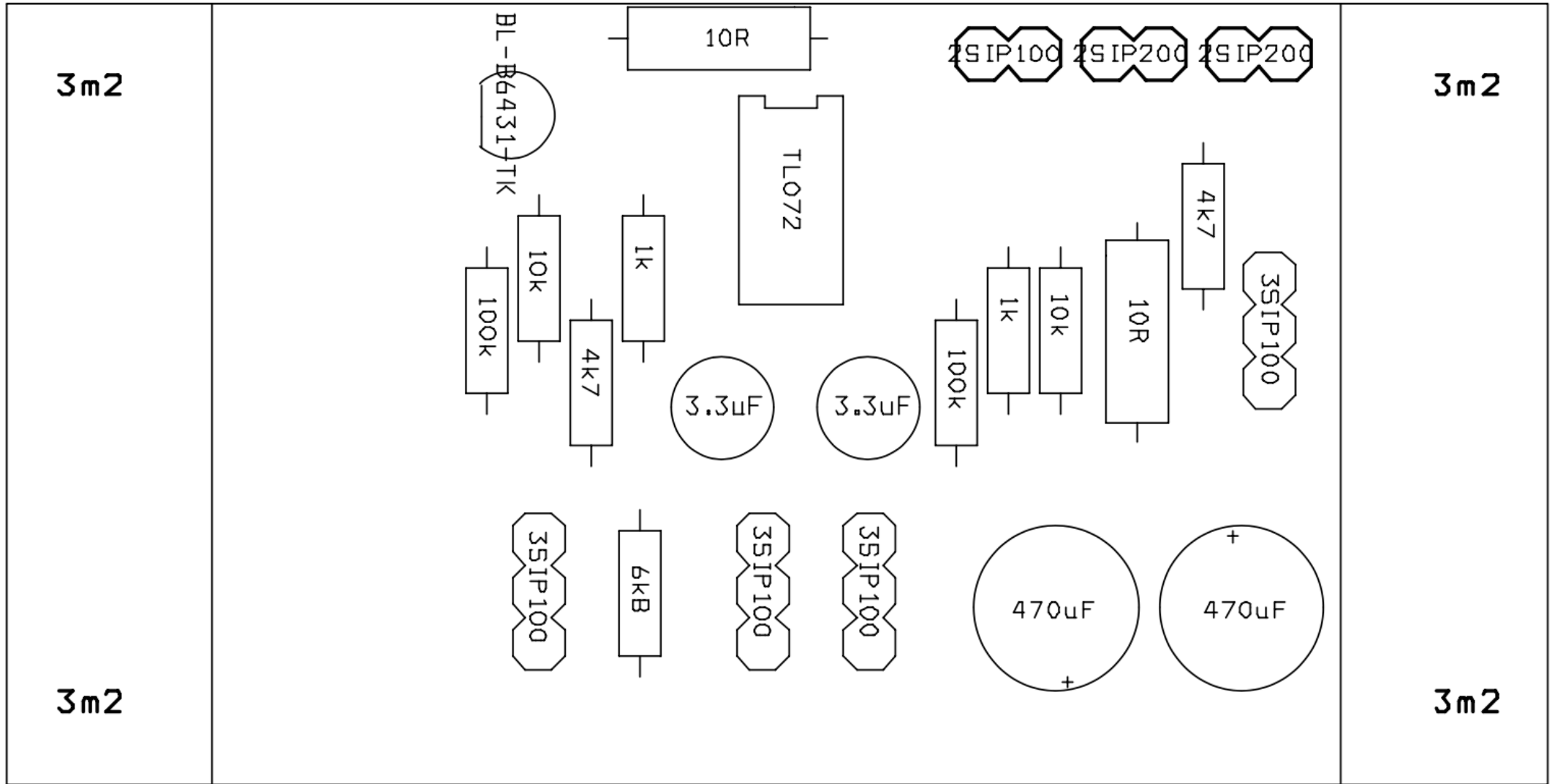

Assembly - Top

Soldering with examples of a dry solder joint

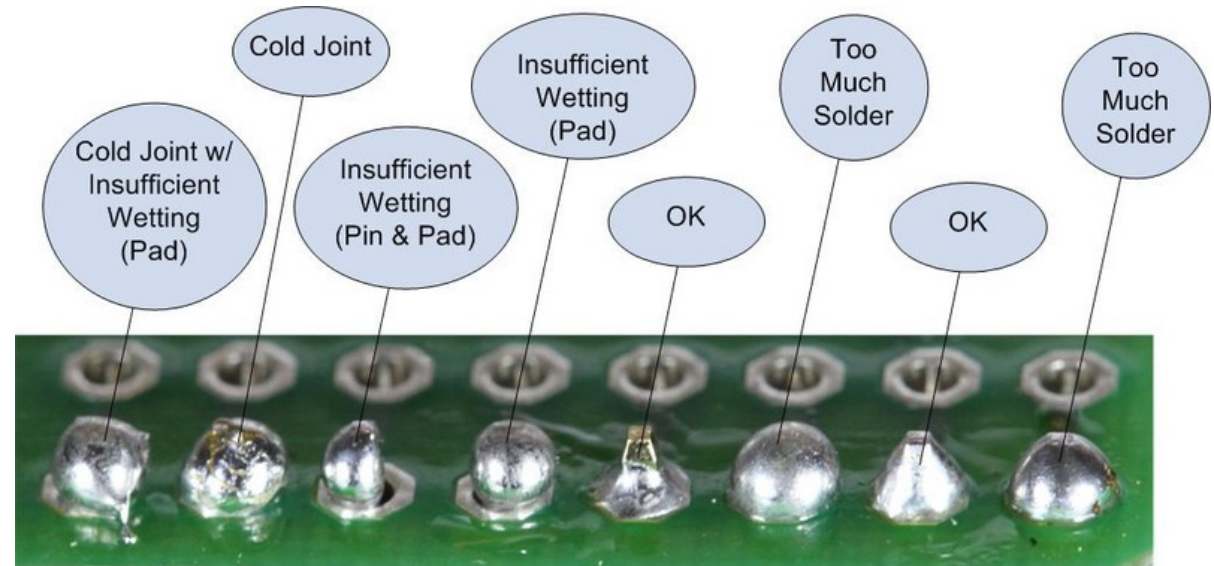
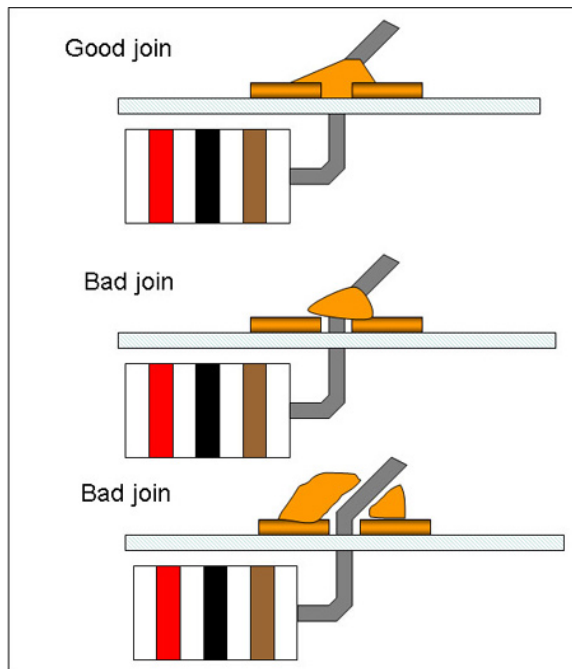
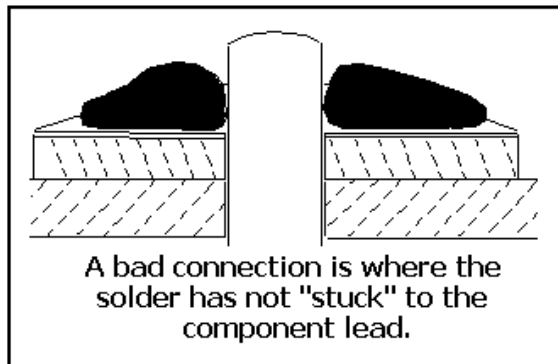

Always ensure that the joint is not moved whilst cooling, this will cause a matt finish. A shiny joint will be correct joint.

Please ensure that you use a fine tipped soldering iron
DO NOT OVERHEAT JOINTS WHEN SOLDERING

Cable “Left and Right” connections

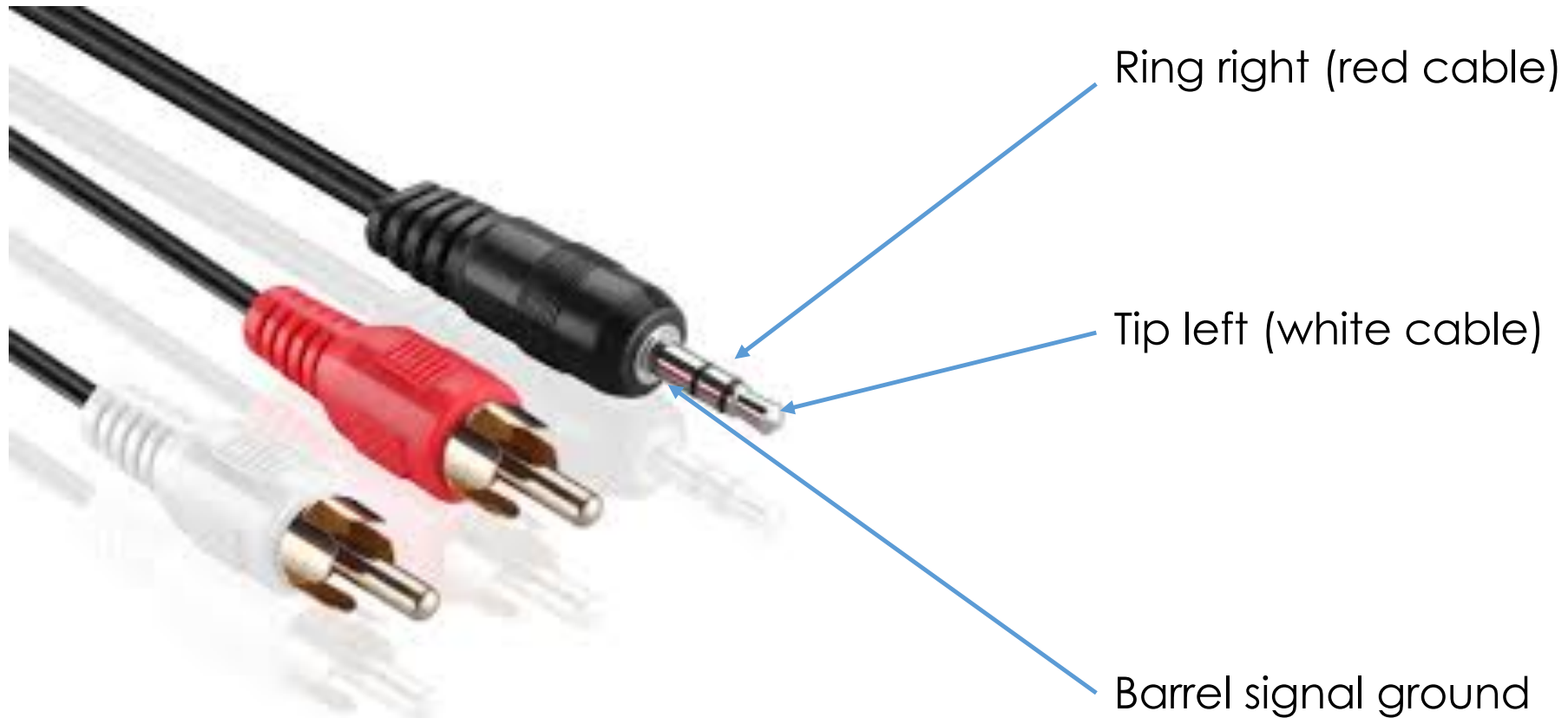

Please note ! We have noticed some dodgy cables that are swopped around..always test with a cell phone app to confirm left and right.

Resistor component codes

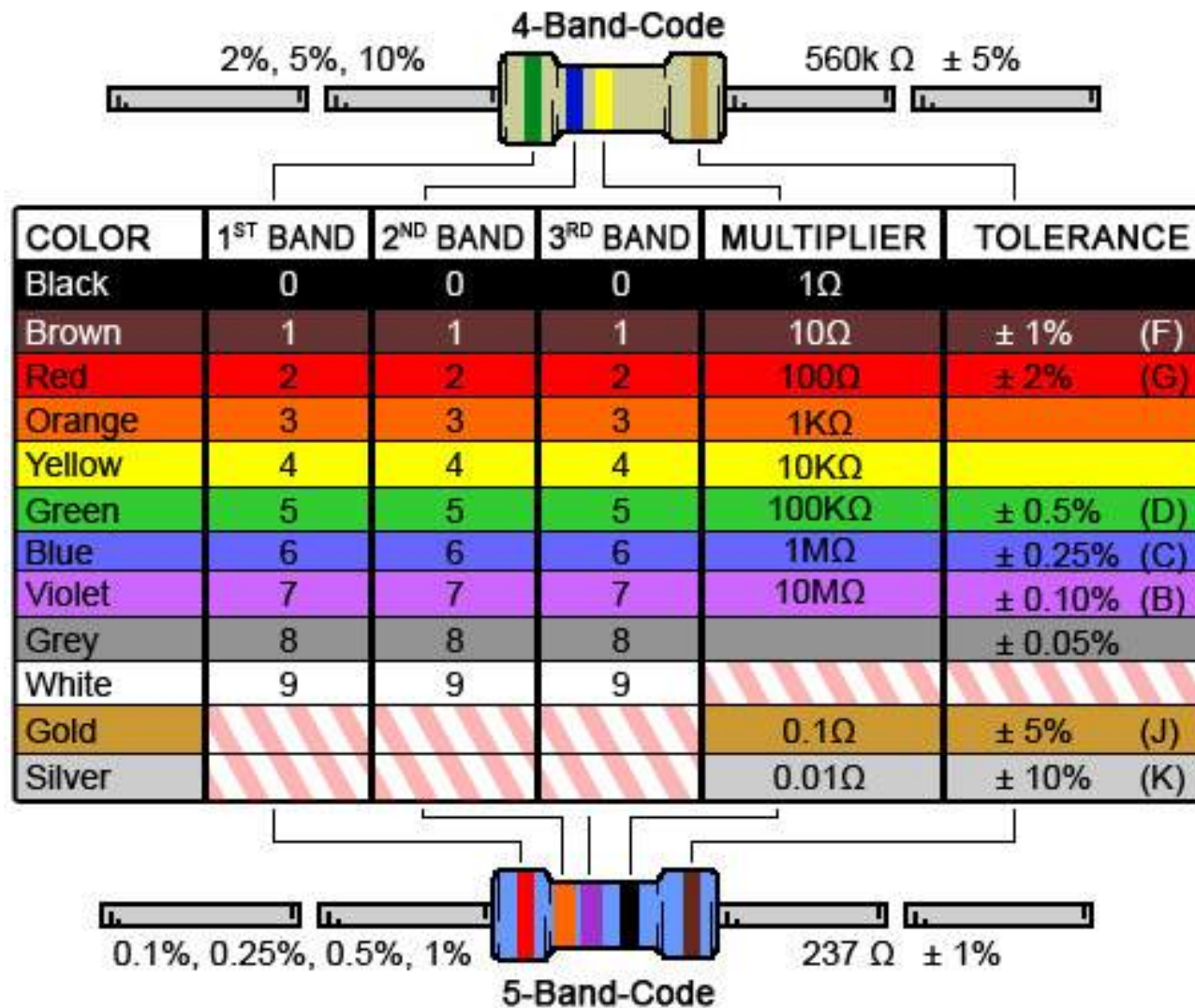

If in doubt, always check values with a multimeter

Diode mounting

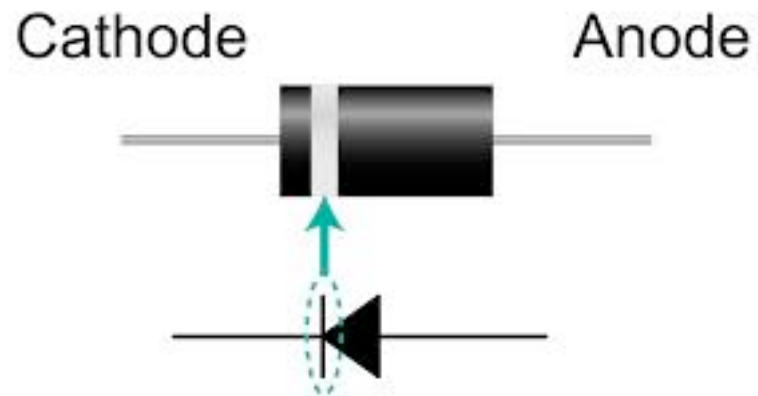



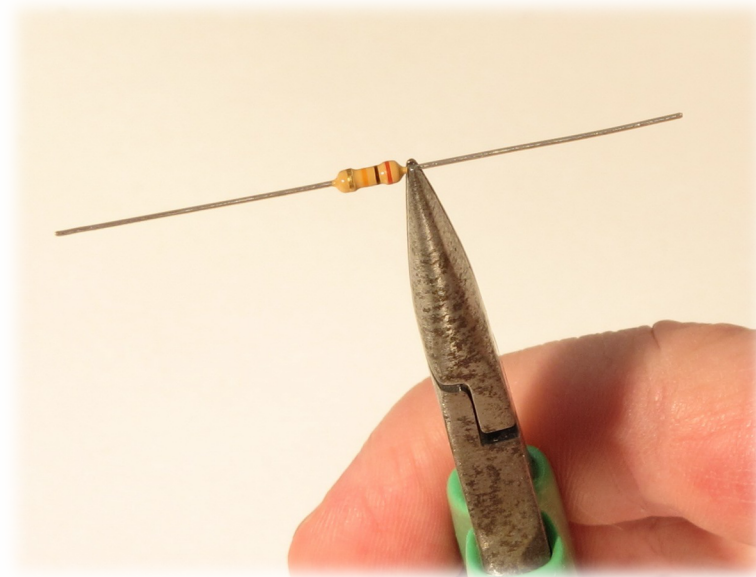

Always ensure a diode is correctly inserted to the PCB or the system will not work.

Bending a component lead



Take care when bending a component lead not to damage the “die” of the component. Always use pliers to prevent undue strain on the die.

Capacitor codes

VALUE	CODE	MULTILAYER (270 pF)	CERAMIC DISCS (.001 μ F) (0.1 μ F)	ELECTROLYTIC 1 μ F
10 pF =	100			
100 pF =	101			
1000 pF =	102			
.001 μ F =	102			
.01 μ F =	103			
.1 μ F =	104			

Please note, the capacitors for input audio are electrolytic but non polarised with the long leg as the positive known as non-polar

These are part numbers C1 and C6 value 3,3 uf or also known as 3u3

Power and capacitors are polarised electrolytic, the device is marked and the long leg is always the positive

These are part numbers C4 and C5 value either 220 uf or 470uf

Preparing materials

The first stage is to prepare all materials ready for assembly, then you can focus on the assembly,

NOTE that the Lozenge tin needs to be marked carefully a similar tin to Fisherman's Friend is ideal

The PCB has to be separated as required, if using a wooden enclosure, 4 screw holes are provided

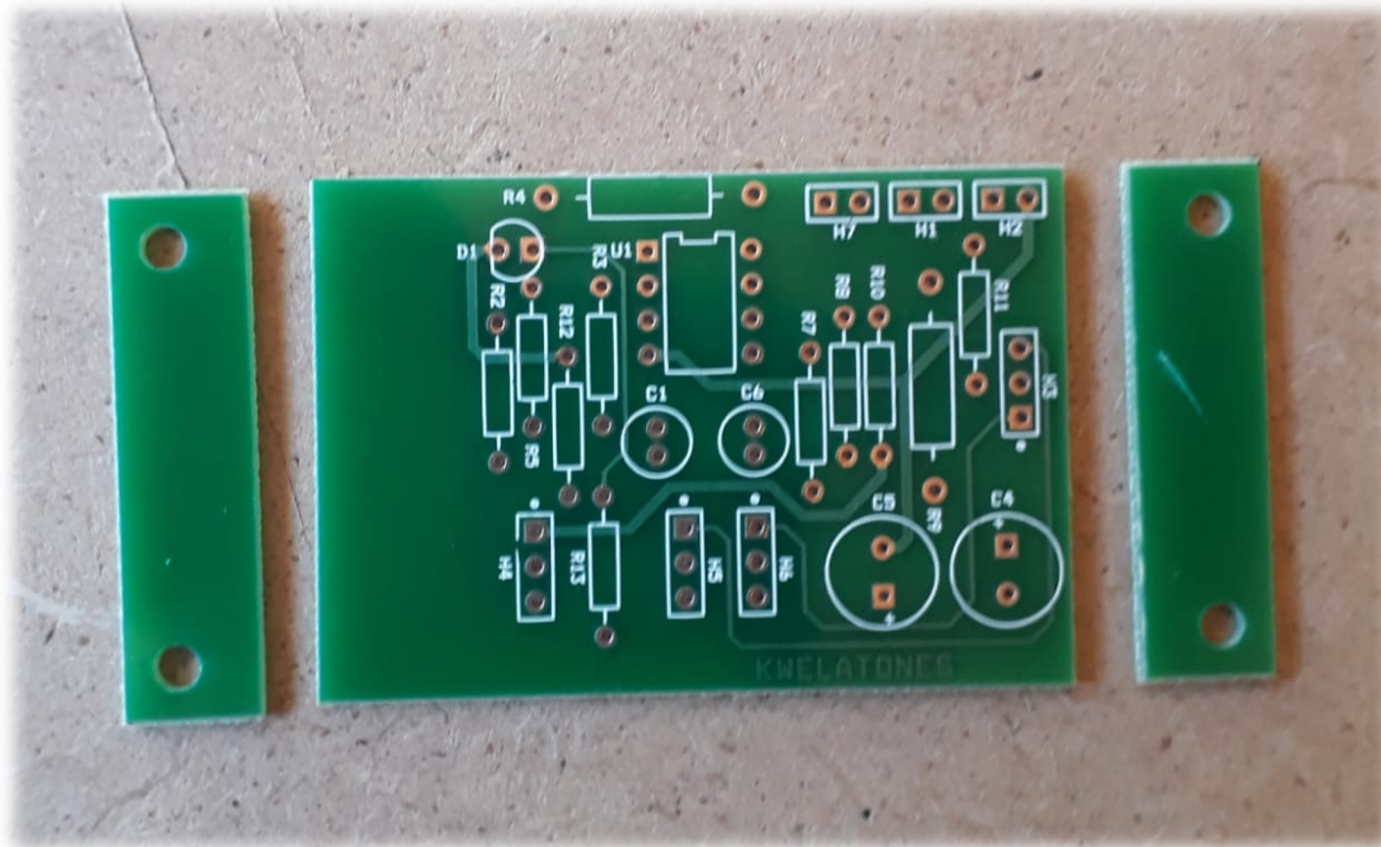

Preparation of the tin for drilling

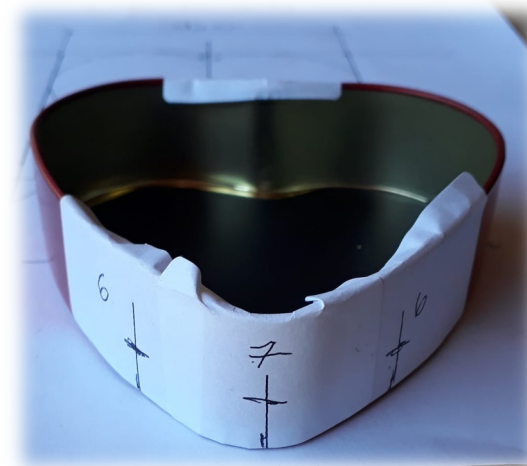
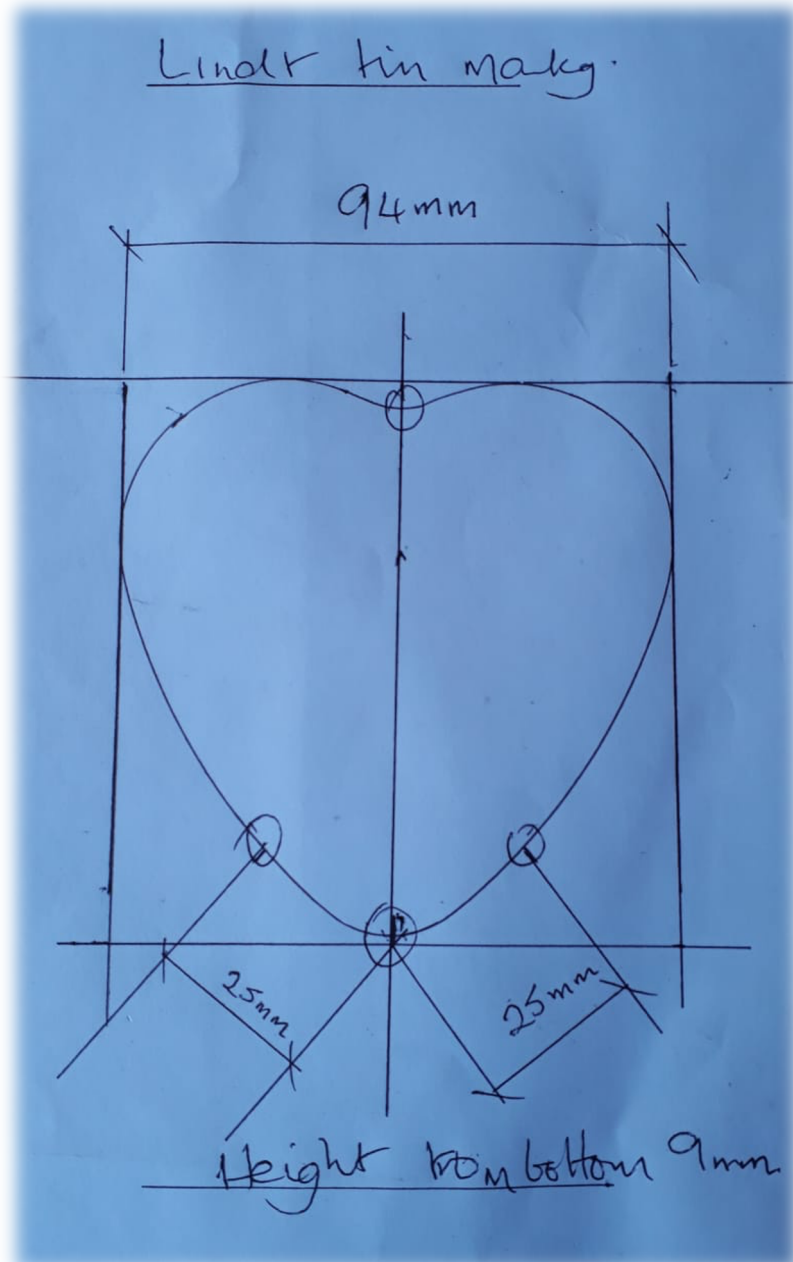

Then apply masking tape to the tin and mark the positions of each hole, mark the hole centre 9mm from the bottom. from the bottom. Lightly centre punch each centre holes are as per the labels, 7 mm for volume and 6mm for the switch. Mark light hole as per your choice. (1,5 mm) Hole height from the bottom is 9 mm

Spare labels are provided for this purpose.

Preparation of the tin for drilling

Firstly let's mark the tin, the simplest way is to mark a sheet of white paper with the tin's outside dimensions on it. Then mark the matrix to drill holes.

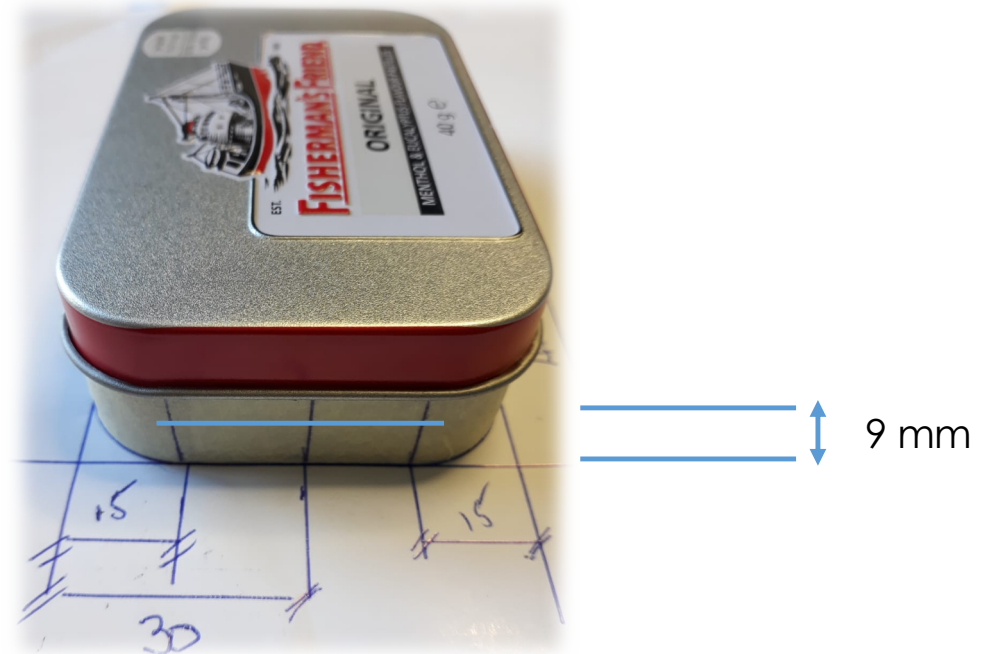
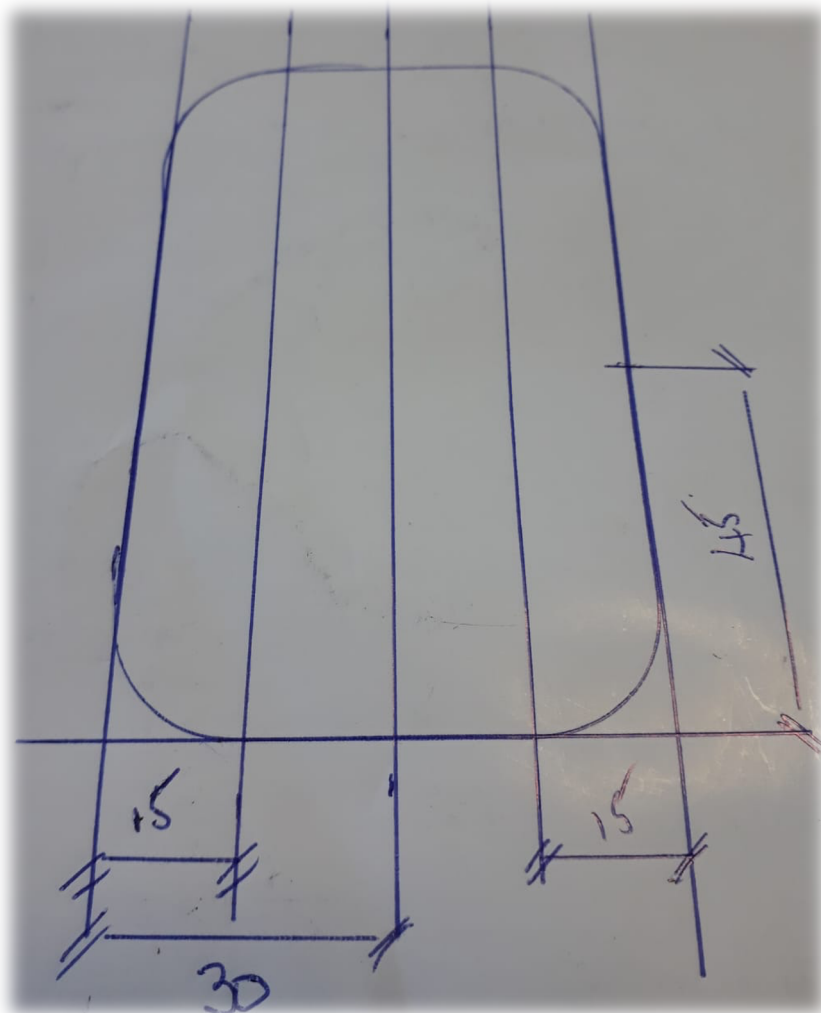

Then apply labels to the tin and mark the positions of each hole, mark the hole centre 9mm from the bottom. Lightly centre punch each centre. Volume is 7 mm in the centre and the switch hole and sockets are 6 mm

Pre assembly of tin before assembly

Its always nice to preassemble the tin

Tip 1, **make tea**...mark the vinyl sheet to the perimeter of the tin and apply in the tin.

Then put the parts in the correct spots.

Look listen and decide

To see all is in order.

Now you are ready for the PCB assembly

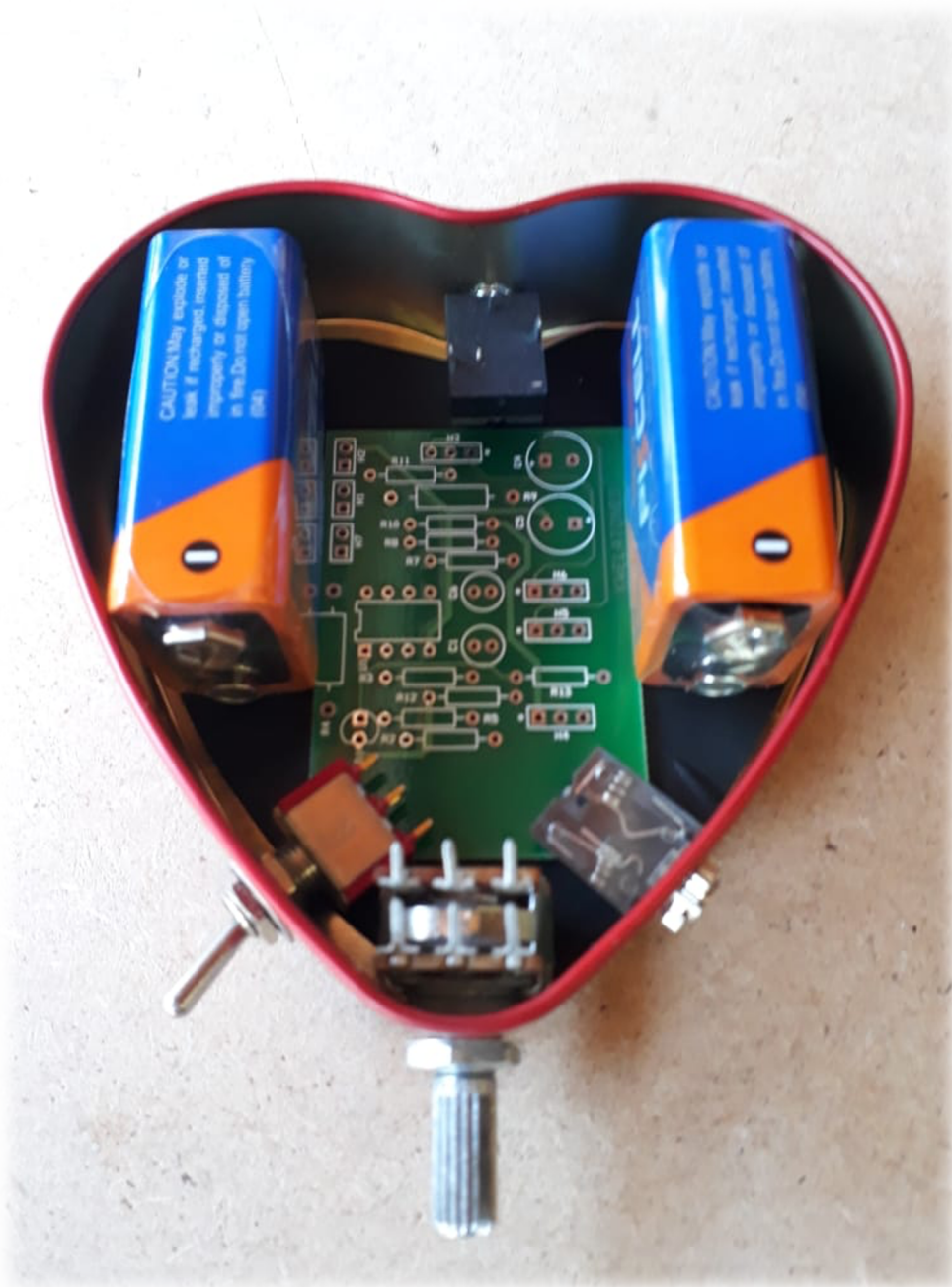

PCB assembly

The PCB is very carefully designed to allow a kit builder to assemble without errors.

As it has two sizes of components, its easier to assemble in the following order, remember to keep the gold band in the same direction when assembling resistors as it makes it easier to read the components.

Open the packets when you need to use them !

Start with the two 10R resistors and the two 4k7 resistors which are ½ watt footprint, then proceed with the other resistors.

Then the caps, check the positive and negative orientation, the long lead is the positive. Then finally the LED, the flat on the side is negative. Then the DIP I/C socket. Don't overheat the PCB on assembly....

NOTE if using polarized caps for C1 and C6 ensure the negative is towards the input from the pot !

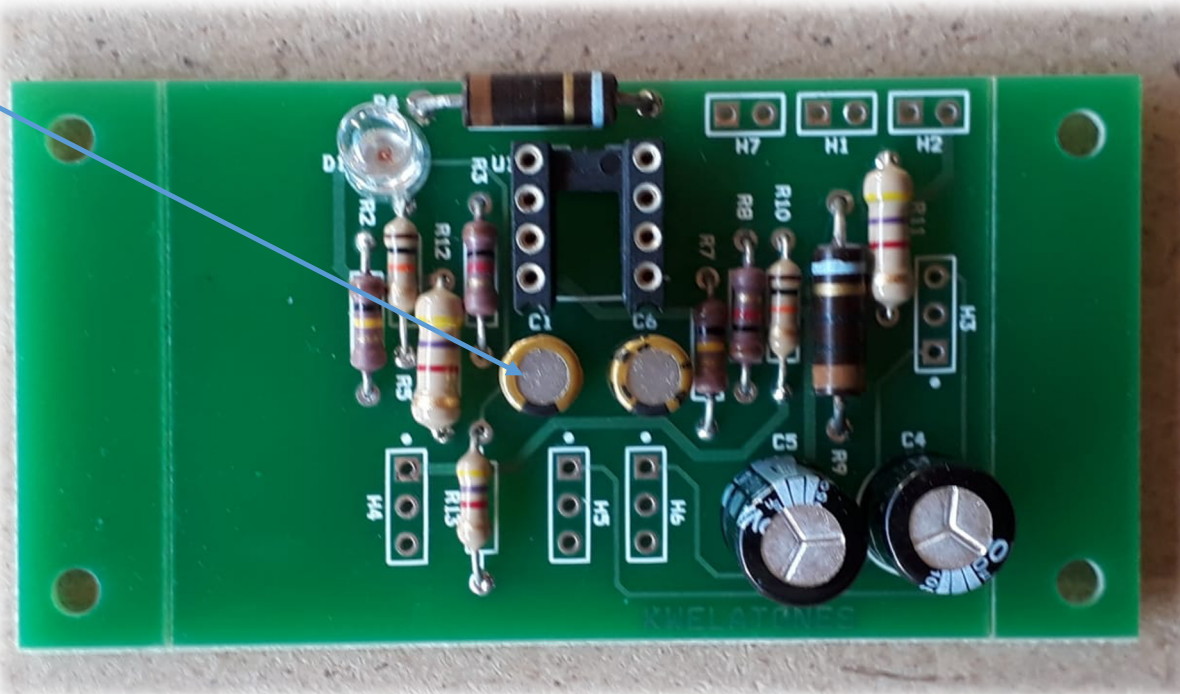

Op Amp connections (for reference)

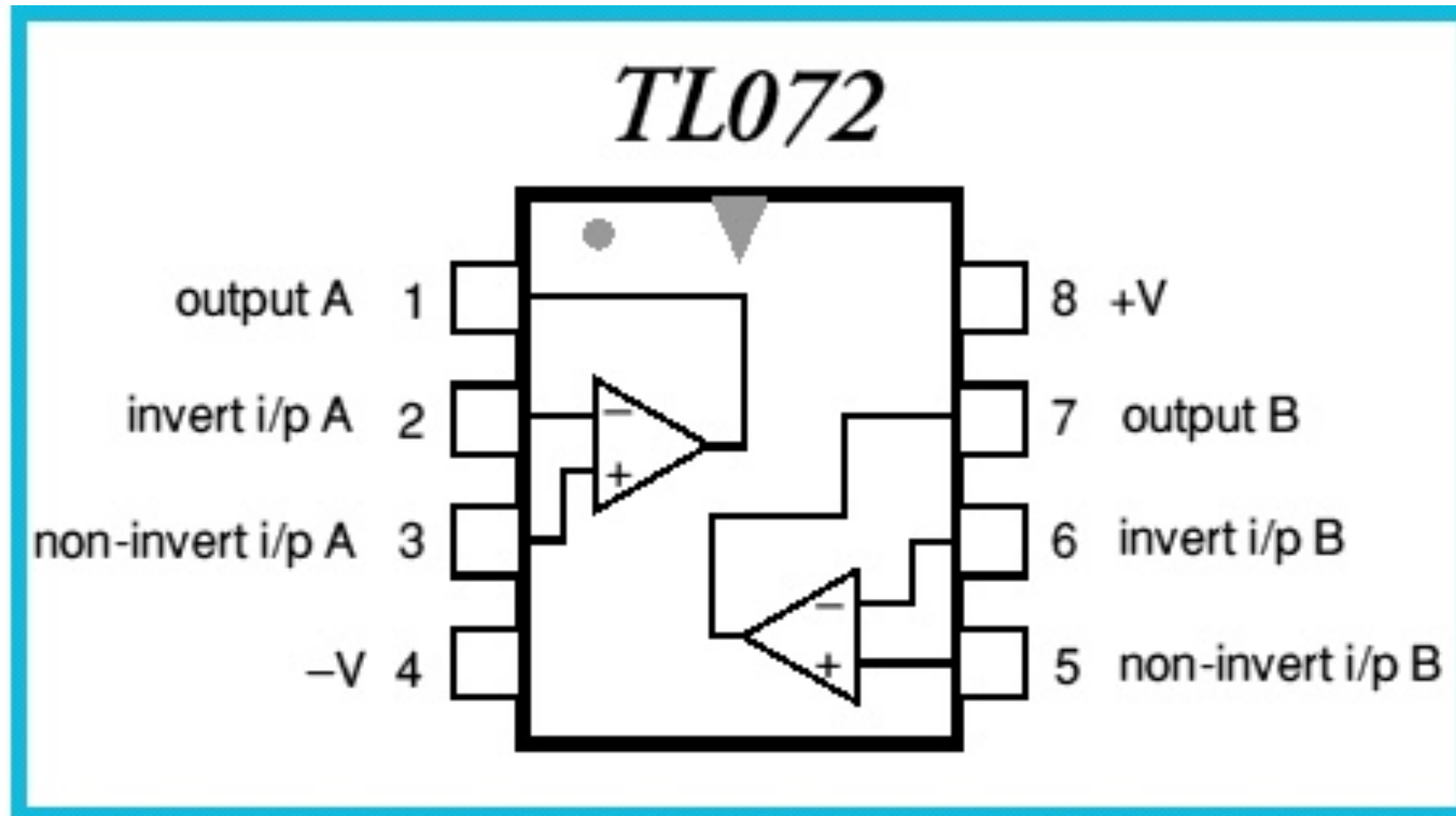

Its nice to trace the tracks and see these connections

Connect the audio output jacks

When connecting the audio socket, take note of the tip and band connection. The tip is the left signal, check this with a aux cable and a multimeter for continuity.

Connect the yellow wire to the left connections, the right wire is orange. Ensure a heat shrink is placed over the solder joint to tidy the assembly on completion.

The black wire goes to the barrel. Three wires are required for the headphone connection.

Solder the three cables to make a neat joint. Twist wires (remember that you look at it).

The pp3 cables are complete with cables, these are connected to 2 connections H1 and H2 Red to positive and black to negative. Solder the cables onto the PCB as explained. The switch is connected to H7.

Remember ! Always twist cables together and keep as short as possible.

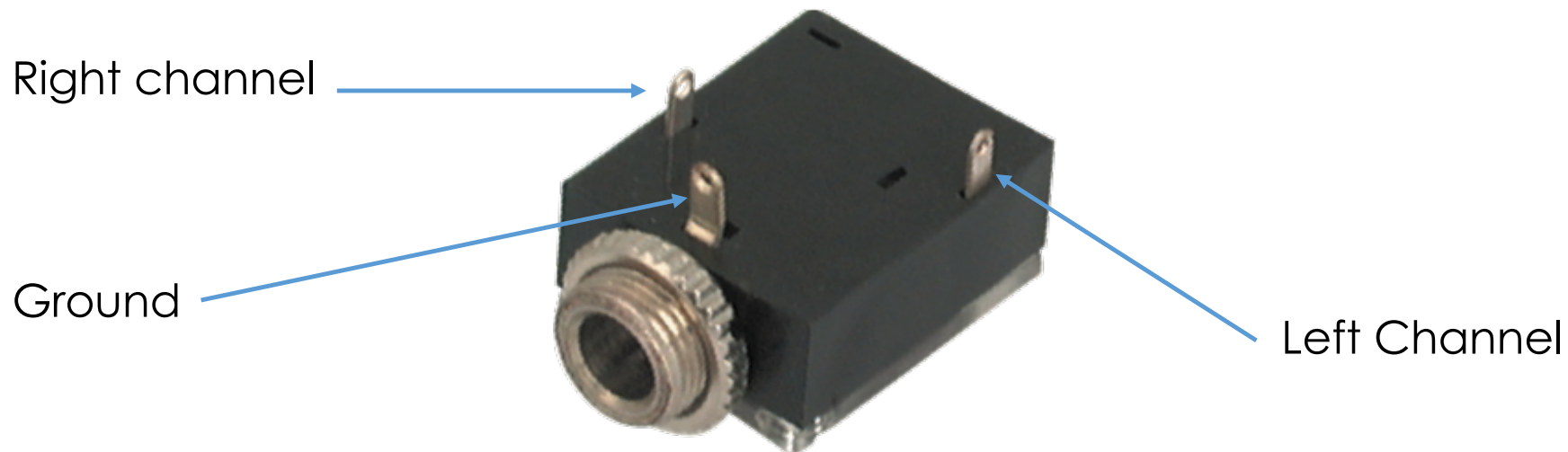

Connect cables to controls

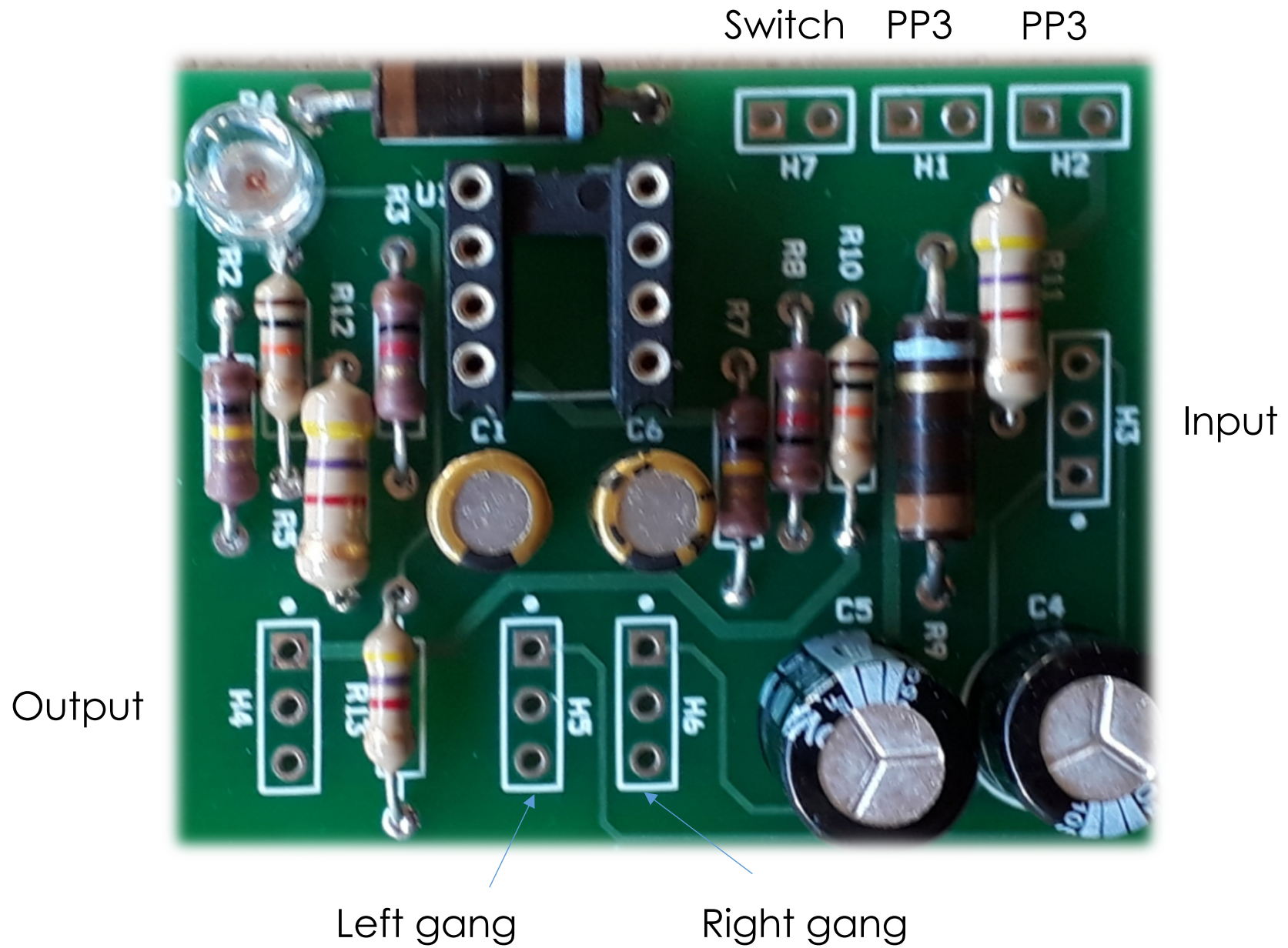

Power, Input and Output

Switch
(no polarity)

Battery

Battery

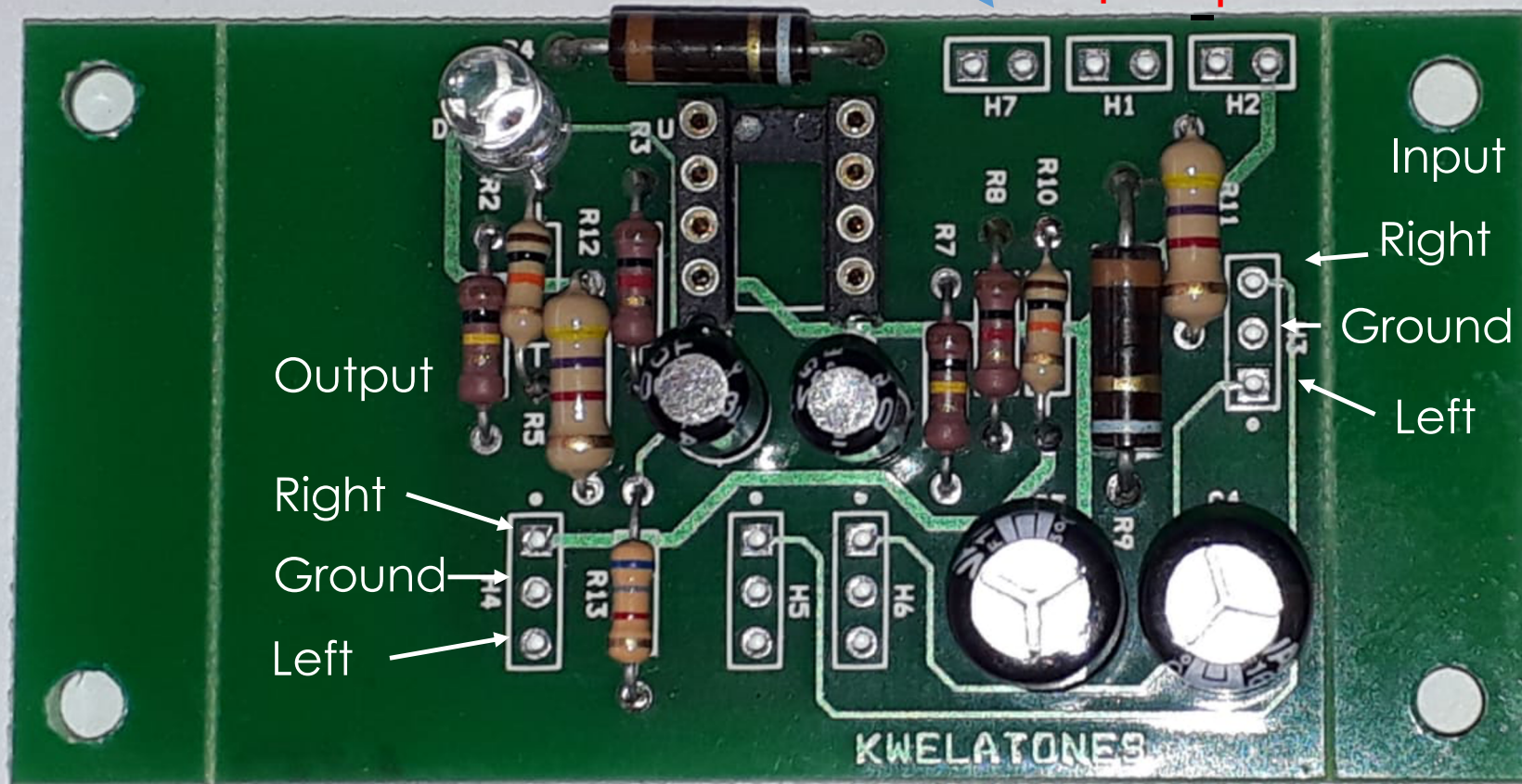

Volume control connections

Orange is right (top gang) and (yellow is left gang)

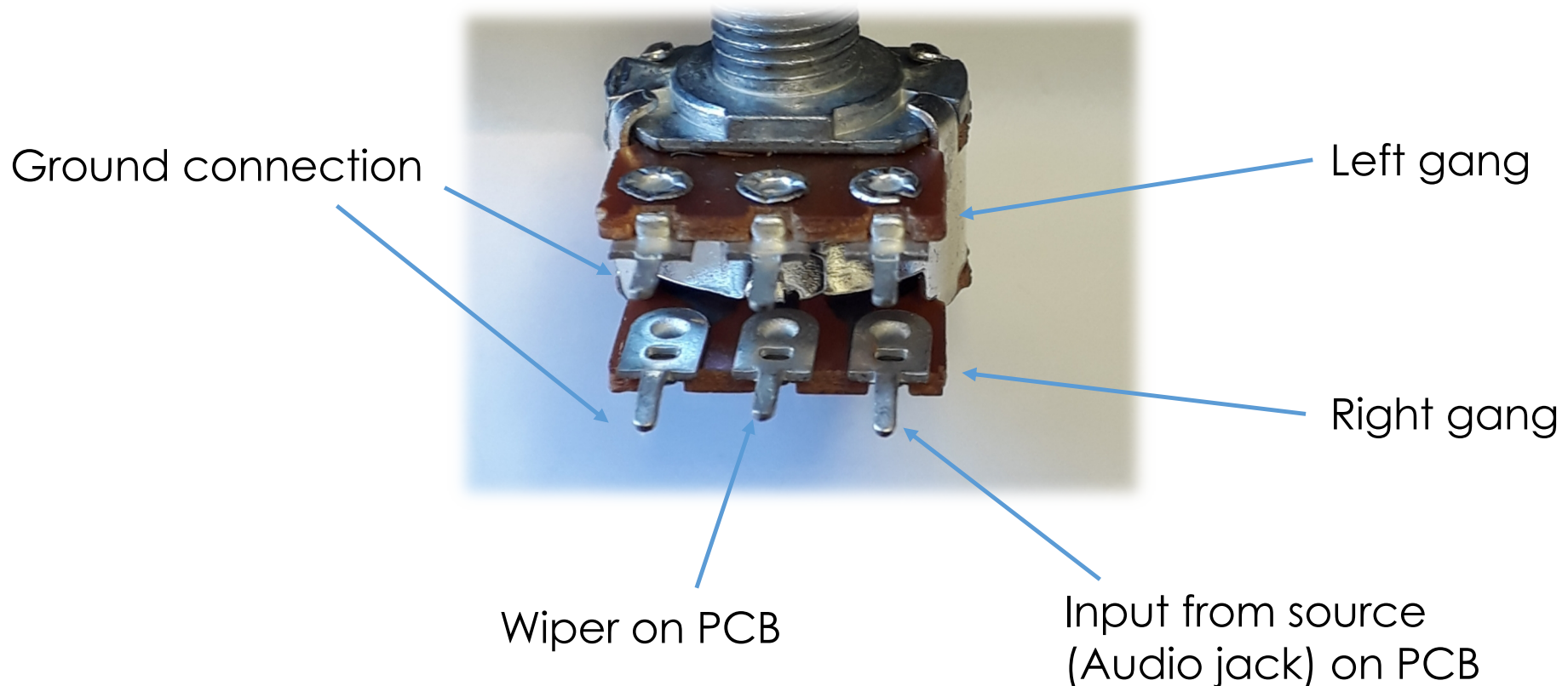

A dual gang audio taper volume control is used type A10k
Heat sleeve is provided to insulate conductors before installation

Volume control connection

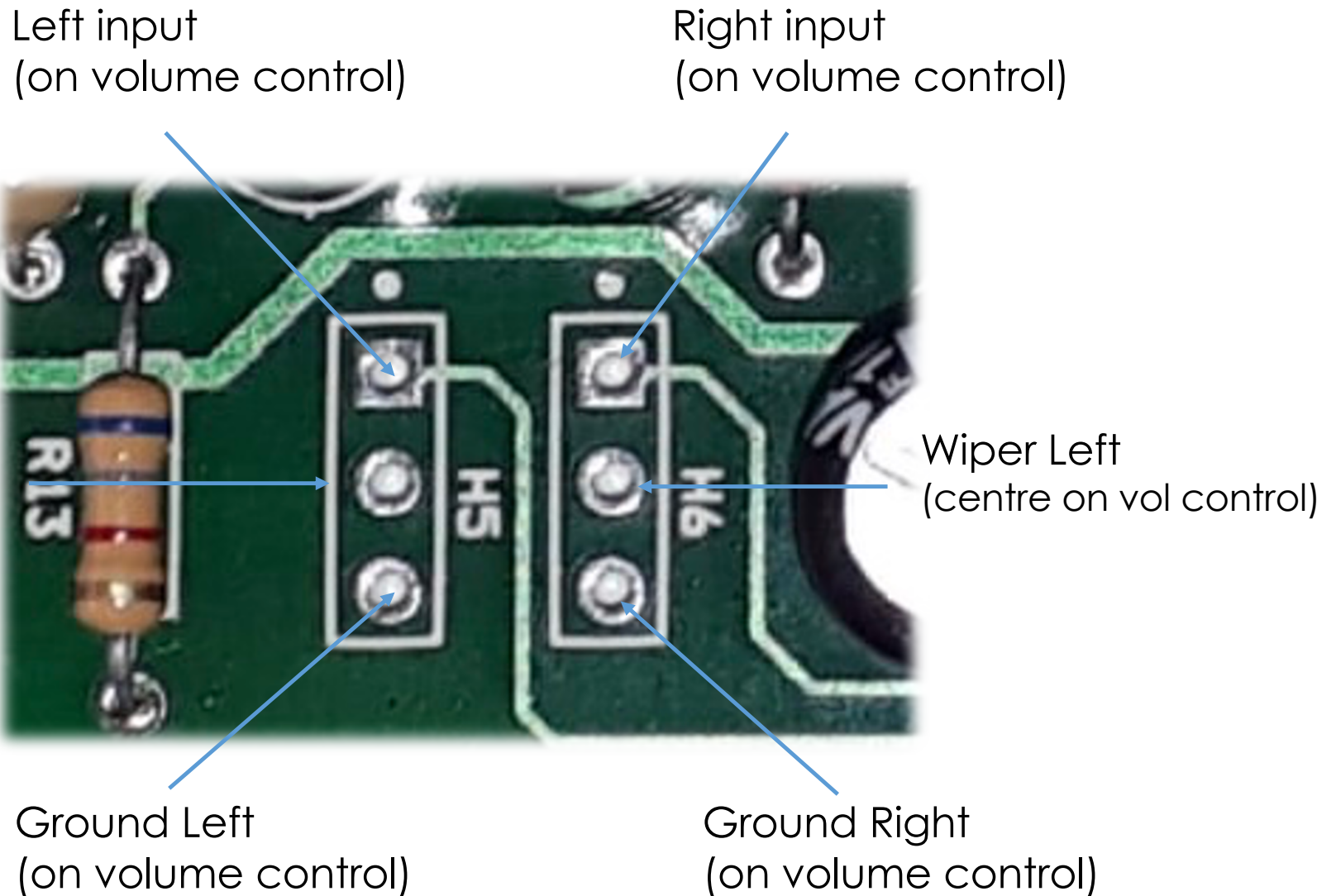

Now the cables

Use green or black for earth or ground
Red for the switch
Yellow for the right channel
Orange for the left channel

Note the header for the input and output
Is marked with a dot for the right channel
See H3 and H4

You will have to measure in the tin for
cable lengths as per your position
choice.

When connected to the sockets and switch
place Prestik under the PCB and secure
to the tin on the vinyl.

After all cables are connected, clean the
PCB with benzine and a toothbrush to
remove flux.

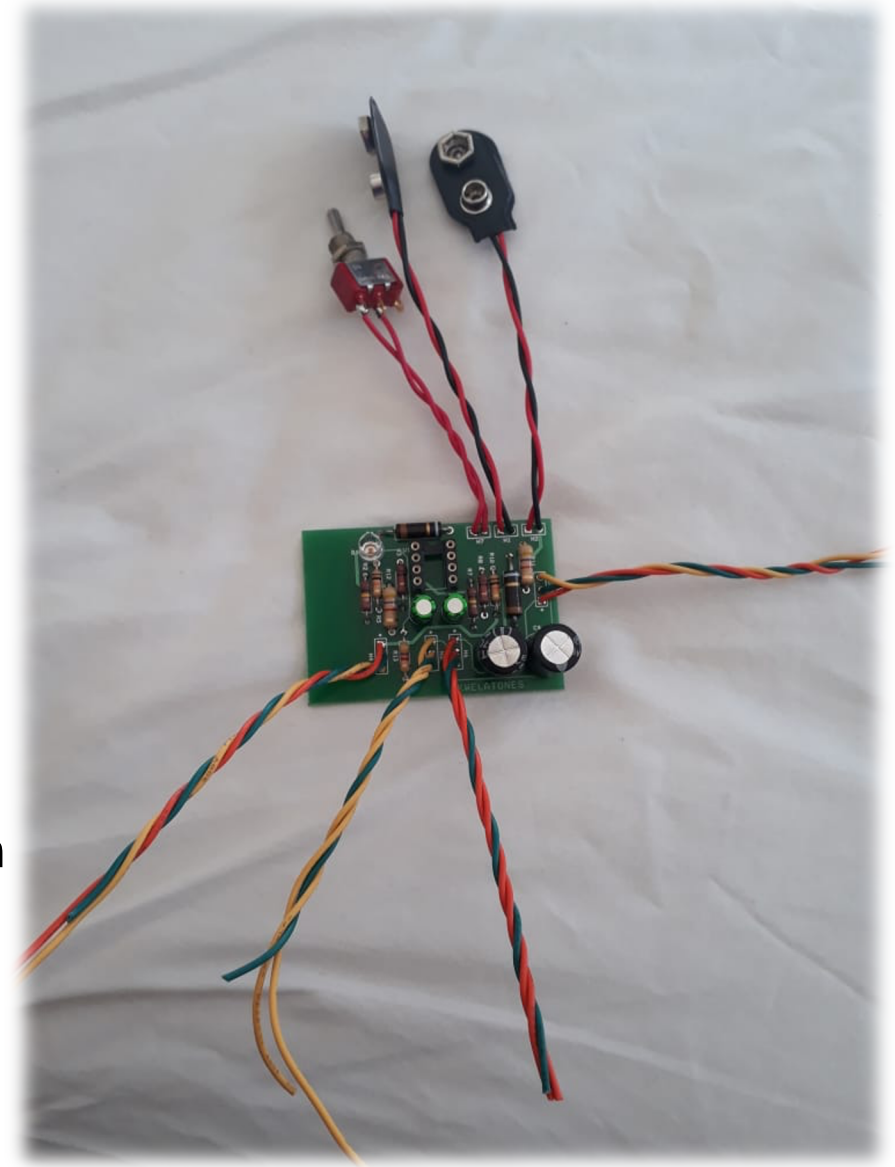

LED window, drill with a 1 mm drill this to suit your taste and also enclosure

Mark and drill a small 1,5 mm hole for LED
above the switch allowing a small clearance



Testing

Before connecting the device confirm the following :

All solder joints are confirmed to be in a shiny condition, or NOT dry joints

Switch on confirming LED light works before connecting audio input and headphone cables

**ALWAYS SWITCH ON WITH THE VOLUME CONTROL AT
MINIMUM TO AVOID HEADPHONES DAMAGE**

Download a cell phone app that shows left/right audio and plug in a aux cable to the side. Plug in headphones.

Check left/right, this will show that the system works. If not correct, change the left right audio output cable to suit.

Note, we have seen some aux cables with left/right swopped over so always check with the intended cable that will be used.

Before closing the lid, ensure nothing fouls, fit knobs and you are good to go



Op Amp Rolling

The Kwela tones is ideally suited for OP Amp Rolling...

Firstly..What Is Tube Rolling?

Lint audio make a range of Tube amps (in the UK, its called a valve)

Simply put, tube rolling is the process of trying out a variety of different tubes in the same socket in an amplifier in order to find the one that sounds best to you. The name comes from the circular rolling motion used to slide the tube's connection pins out from their sockets in the amp.

The quest for the next best tube, meaning the one that sounds different or better than the one your amp came with or the one that you're currently using, is what makes tube rolling so addicting. This is what we mean when we say that tube rolling offers the ability to tweak your music. Depending on your amp, changing tubes can have a big impact on system synergy and the tonal characteristics of your amp. Synergy in a system is all about getting your components to sound best as they work together.

So in this project we call it OP Amp rolling, but we don't roll them, we unplug them ! It's a great place to start at minimum expense. Just remember a 8 pin dual channel jfet op amp in the specs..

As the Op Amp drives the headphone direct, we have included a 10r audio grade resistor for the optimum experience.

Lets cite some examples

TL072	It's a audio grade Op Amp from the 80s and in itself a legend, supplied as standard
LM358	A general purpose Op Amp, ideal for speech and the hard of hearing with TV its not a audio chip
OPA 2164	The real Legend of audio Op Amps, now obsolete..Burr Brown, say no more !
OPA 1642	Its only available in a SOIC package but we supply on a DIP adaptor. Replaces the OPA 2164 and is stunning in its reproduction.
LME 49720	This is a very high end Op Amp and compares with the OPA range of chips.
AD 823	Analogue devices answer to the above, very colourful.

I suggest that you google, have a decent pair of headphones and then experiment before you start on a valve amp !

Suppliers, RS South Africa, Mantech Electronics, Electrocomp, Communica and Mouser (use Electrocomp) to import and Farnells (use Mantech to import)

WARNING

AVOID LISTENING AT HIGH VOLUMES TO PREVENT HEARING LOSS

The **KWELX TONES** will provide many hours of listening pleasure, it is supplied With a TL072 op amp, this may be improved on with different types of Op Amp thus changing the sound characteristics to suit your taste.

Enjoy **KWELX TONES**

P Lintott

www.lintaudio.co.za

June 2020

Lintaudio

Let the hobby begin.....